

# INSTALLATION GUIDE

# AMP RESEARCH Power Step

Nationally Distributed by Bestop

APPLICATION

MODEL YR

PART #

Jeep Wrangler (TJ)

2003–2006

10-03315-10

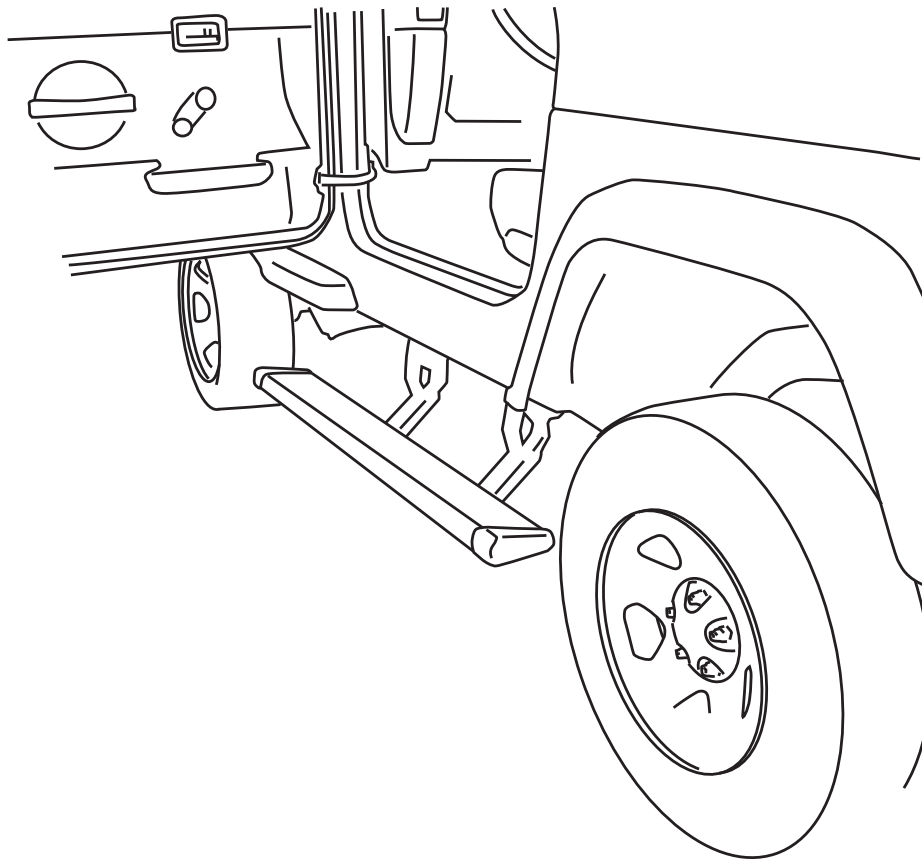

## INSTALLATION TIME



## SKILL LEVEL



4= Experienced

## TOOLS REQUIRED

- Safety goggles
- Measuring tape
- Flat blade screwdriver
- Phillips head screwdriver
- 13 mm socket
- 12 mm socket
- 10 mm socket
- 3/4" end wrench
- 13 mm end wrench
- Ratchet wrench and extension
- Wire crimpers
- Wire stripper/cutter
- Pliers
- 3/16" hex key wrench (allen wrench )
- 4 mm hex key wrench (allen wrench )
- Electrical tape
- Weather proof caulking (silicone sealer)

TECH SUPPORT 1-888-983-2206 (Press 5 for Customer Service) Monday - Friday, 8:00 AM - 5:00 PM PST

Designed and manufactured by AMP Research. Patent 6,830,257 / 6,641,158 / 6,834,875 / 6,938,909 / 6,942,233 / 7,007,961 Other US and worldwide patents pending. Three-year limited warranty. Professional installation is recommended. Nationally Distributed by Bestop.

PARTS LIST AND HARDWARE IDENTIFICATION

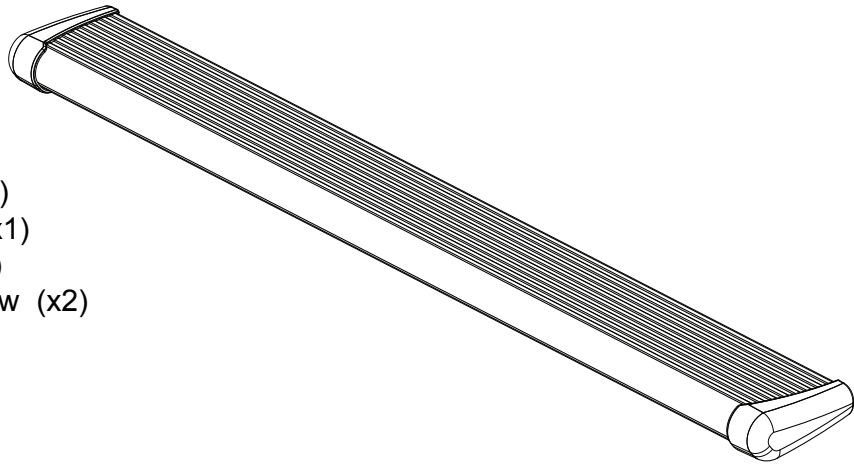

- 19-03199-11 End cap left (x1)
- 19-03199-12 End cap right (x1)
- 19-02663-90 T-nut insert (x2)
- 19-03236-90 Socket cap screw (x2)
- 19-03237-90 Nut plate (x2)

**1** x2 20-03318-48  
Step assembly

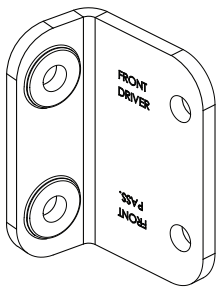

FRONT BRACKET

**2** x2  
16-03275-90  
Front Bracket

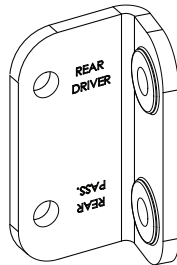

REAR BRACKET

**3** x2  
16-03276-90  
Rear Bracket

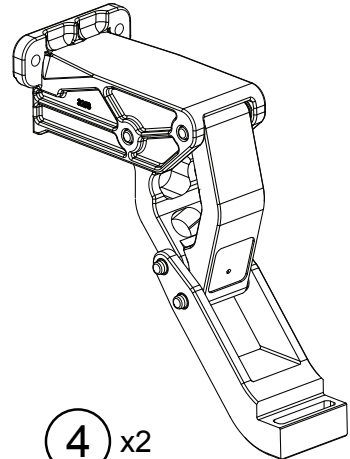

**4** x2  
10-03317-10  
Idler Linkage

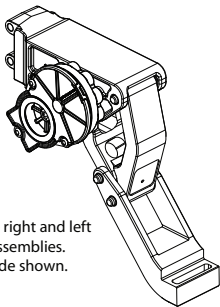

There are right and left driving assemblies. Drivers side shown.

**5** x2  
10-3316L-10  
Motor Linkage Passenger Side  
10-3316R-10  
Motor Linkage Driver Side

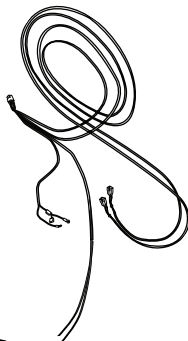

**6**  
19-03309-90  
Wire Harness

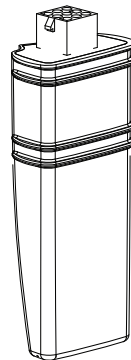

**7**  
19-03297-93  
Controller

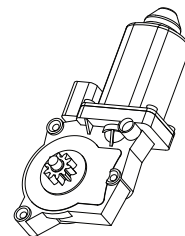

There are right and left motors. Drivers side shown.

**8**  
19-03129-11  
Motor Driver Side  
19-03129-12  
Motor Passenger Side

AMP RESEARCH POWER STEP – JEEP WRANGLER

PARTS LIST AND  
HARDWARE  
IDENTIFICATION

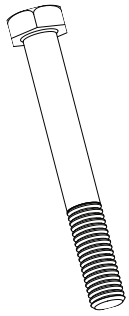

**9** x4  
19-03319-90  
Hex Bolt

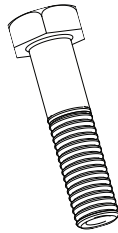

**10** x8  
19-03326-90  
Hex Bolt

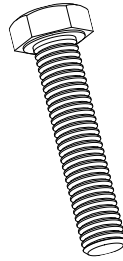

**11**  
19-02487-90  
Socket Cap Screw

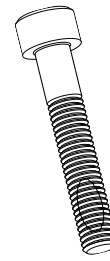

**12** x6  
19-03179-90  
Socket Cap Screw



**13** x8  
19-02802-90  
Socket Cap Screw

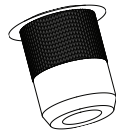

**14** x9  
19-03140-90  
Nut Insert

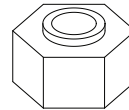

**15**  
19-03205-90  
Rivet Tool

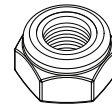

**16** x4  
10-00115-60  
Nylock Nut

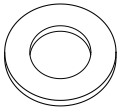

**17** x17  
16-03014-90  
Washer Black

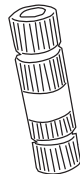

**19** x2  
19-03354-90  
Posi-Taps™ (Red/Grey)



**18** x6  
19-03133-90  
Washer

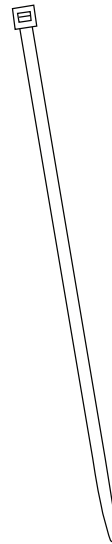

**20** x25  
19-02805-90  
Cable Tie 7"

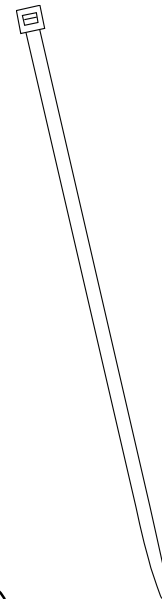

**21** x2  
19-03339-90  
Cable Tie 11"

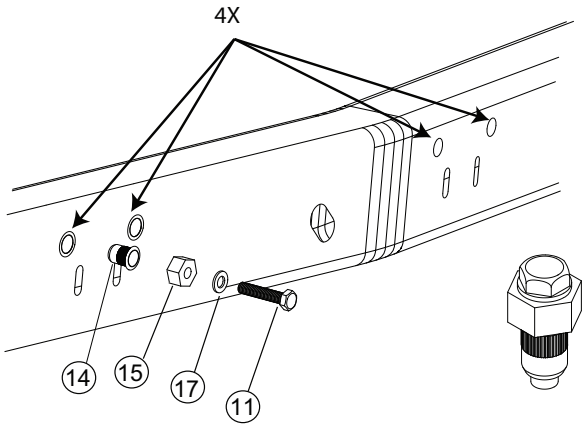

Note: Steps 1-8 shown on drivers side. Repeat these steps on passengers side

Installing rivet nuts

- 1) Assemble rivet nut install tool as shown in figure 1
- 2) Place assembly into hole in frame so that the rivet nut sits flush to frame
- 3) Use wrench to hold rivet nut install tool and tighten bolt (see fig. 2)
- 4) Make sure rivet nut stays flush while tightening bolt.
- 5) Tighten bolt to 30 ft-lbs (41N-m)

1

Make sure rivet nuts sit flush when completely installed

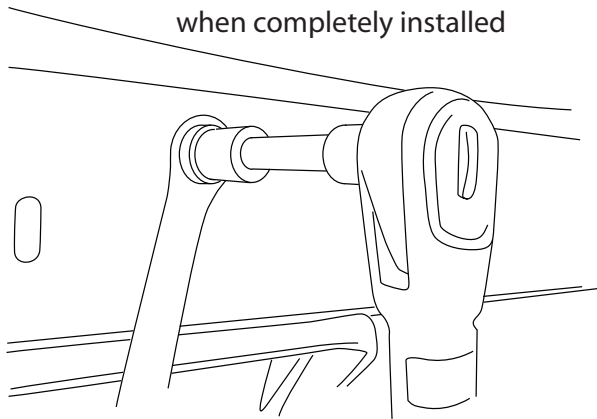

2

Install brackets to driving assembly and top mounting bolt on rear bracket.

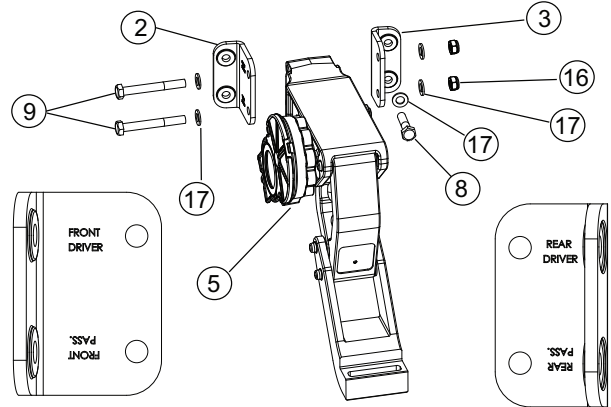

NOTE: Right and left driving assemblies. FRONT bracket attaches to gear assembly side.

3

Install linkage assemblies using M8 x 35 bolts and M8 washers. Do not torque bolts, finger tighten only

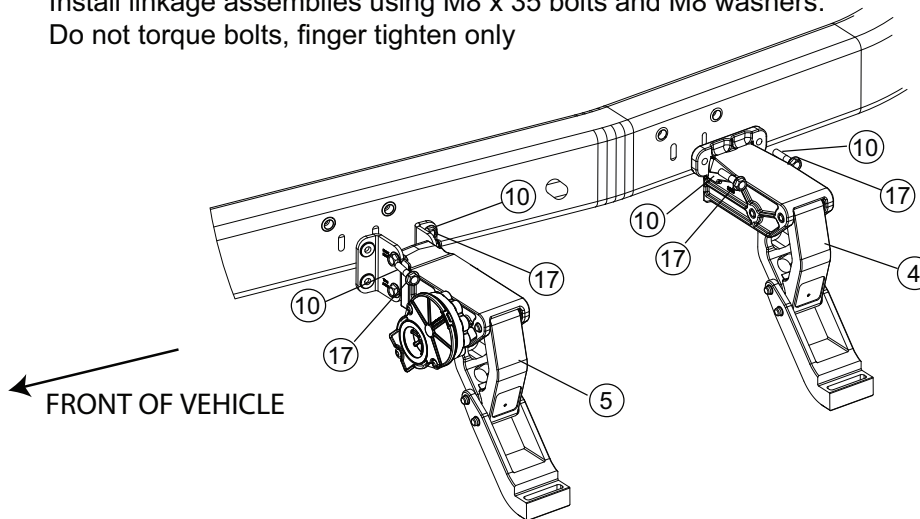

4

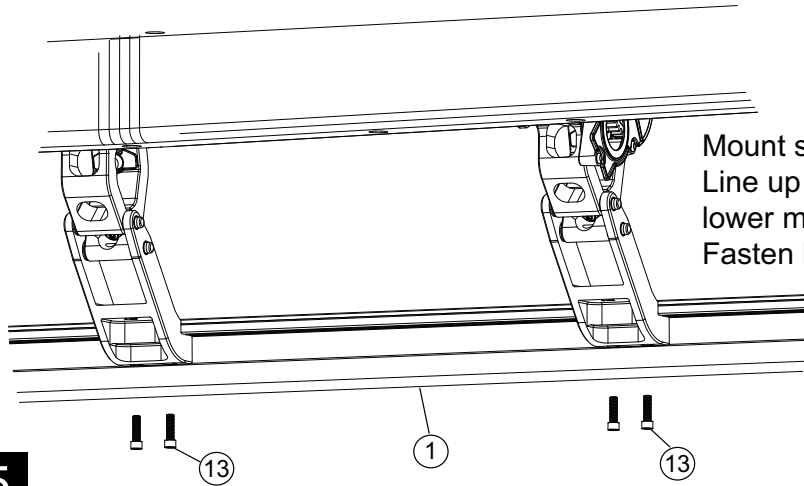

Mount step extrusion to linkage assemblies. Line up t-nuts in step assembly with slots in lower mounts of linkage assemblies. Fasten loosely to allow for adjustments.

5

Line up rear of step extrusion with rear fender well.

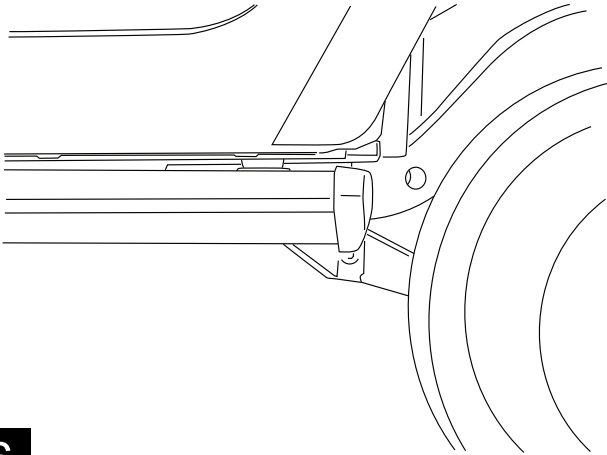

6

Tighten 4 screws with 3/16" allen wrench. Torque to 10 ft-lbs. (13.5 N-m)

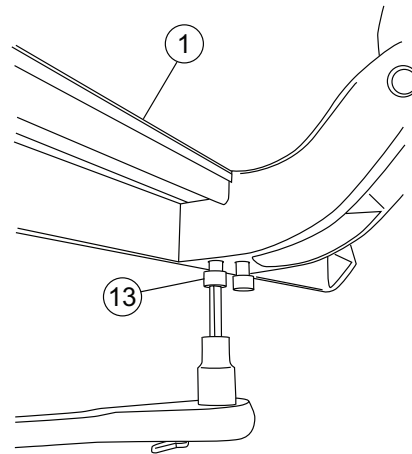

7

Tighten all mounting bolts to frame and bolts to brackets  
Torque to 20 ft-lbs (27N-m)

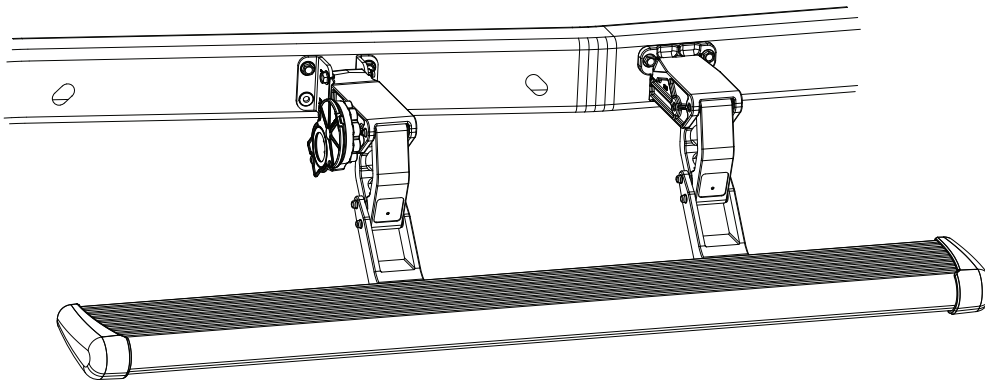

8

AMP RESEARCH POWER STEP – JEEP WRANGLER

Install control box. Use the 2 11" tie wraps to attach controller to factory harness on firewall.

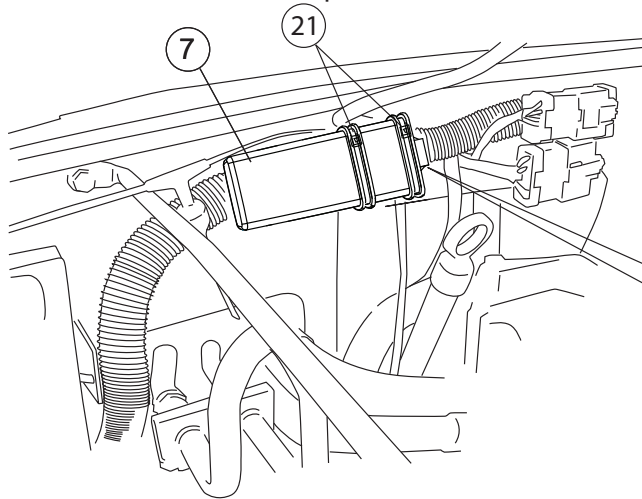

Attach wire harness to the control box

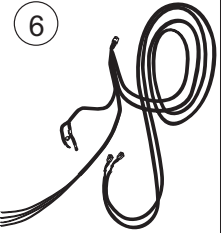

9

Remove fuse from Power Step wire harness.

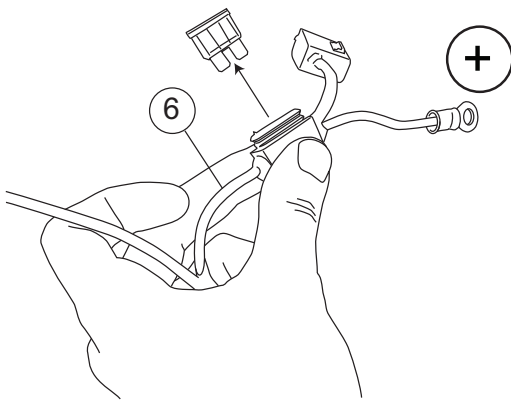

10

Attach power leads, red lead to positive battery terminal and the black lead to the negative battery terminal as shown.

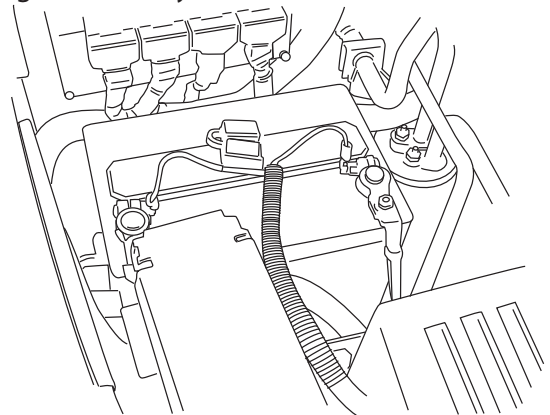

11

Route long end of harness with trigger wires across firewall. Secure with cable ties.

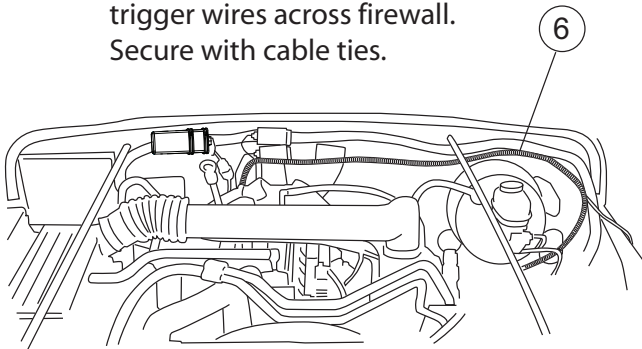

12

Route harness around brake vacuum booster. Secure with cable ties.

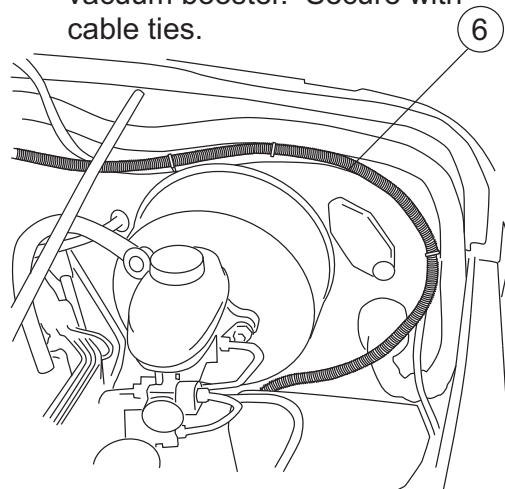

13

Locate grommet in firewall

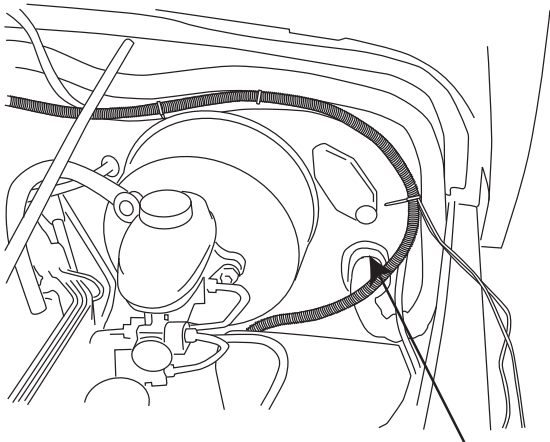

14

Grommet

Route trigger wires through grommet in firewall

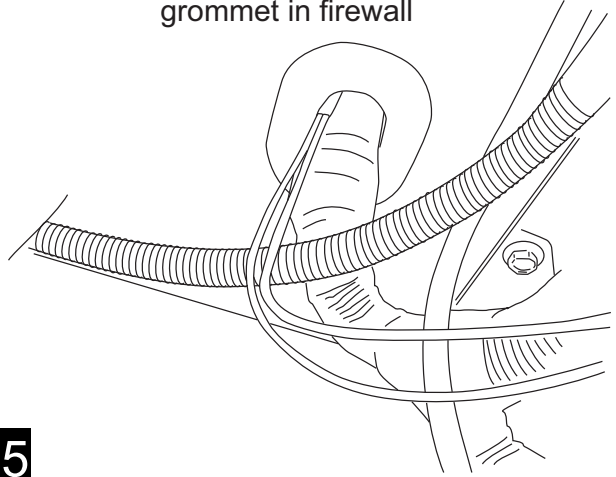

15

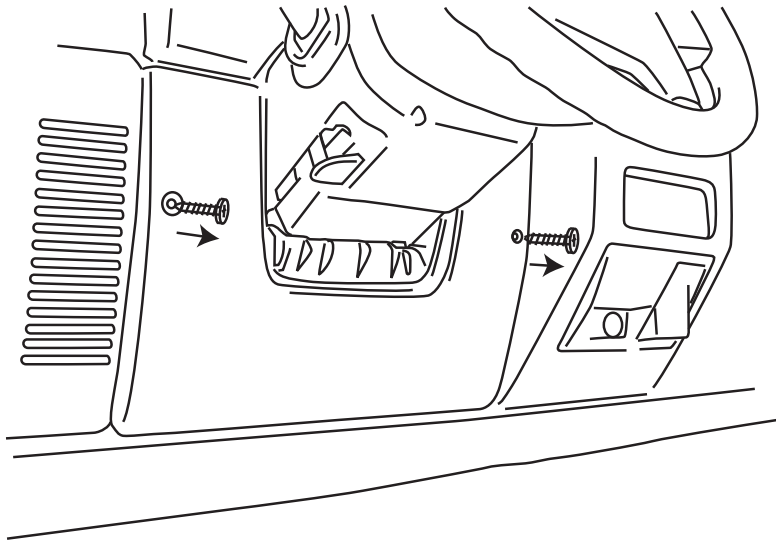

16

Remove two screws and then remove panel

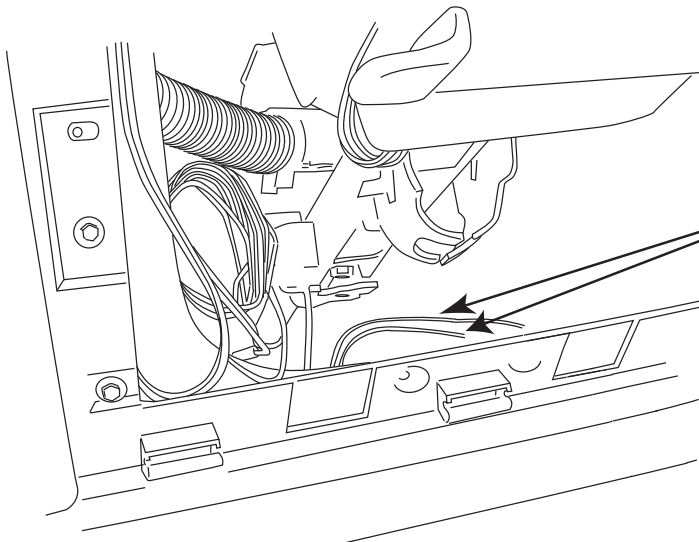

17

Route trigger wires up through panel.

trigger wires

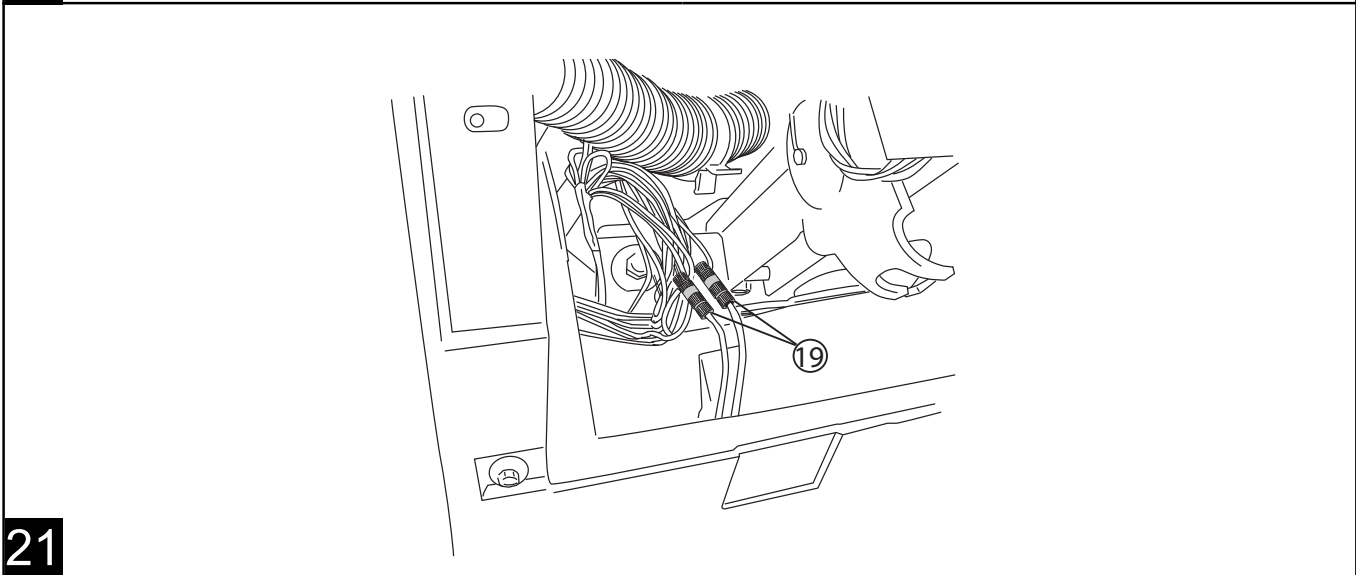
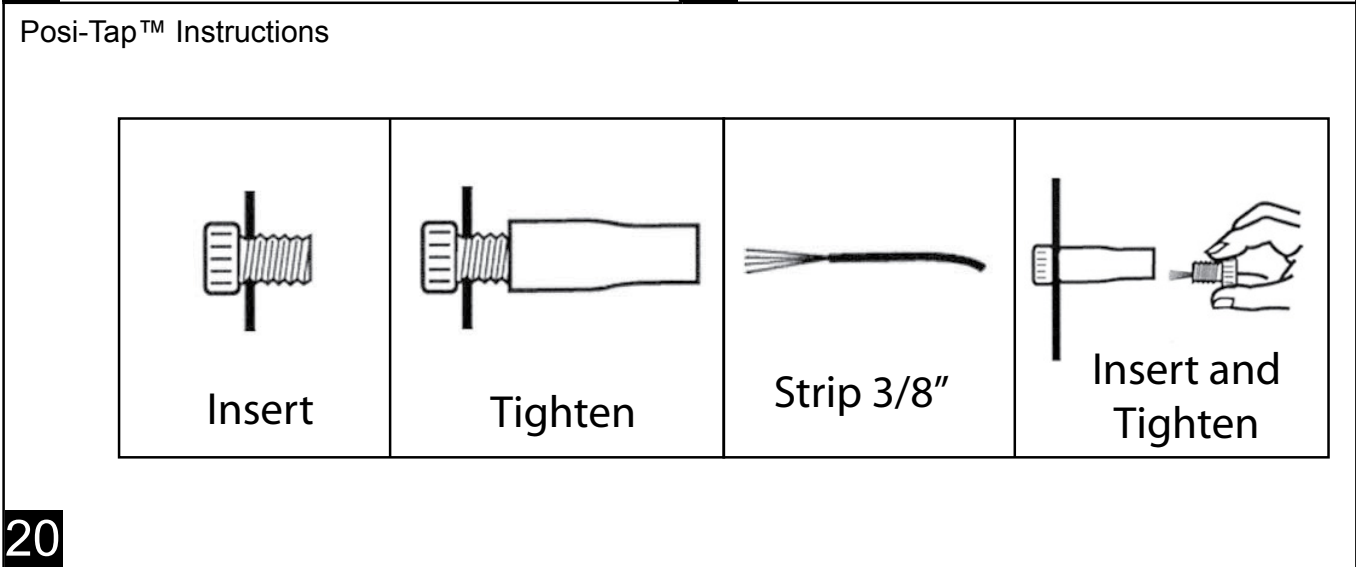
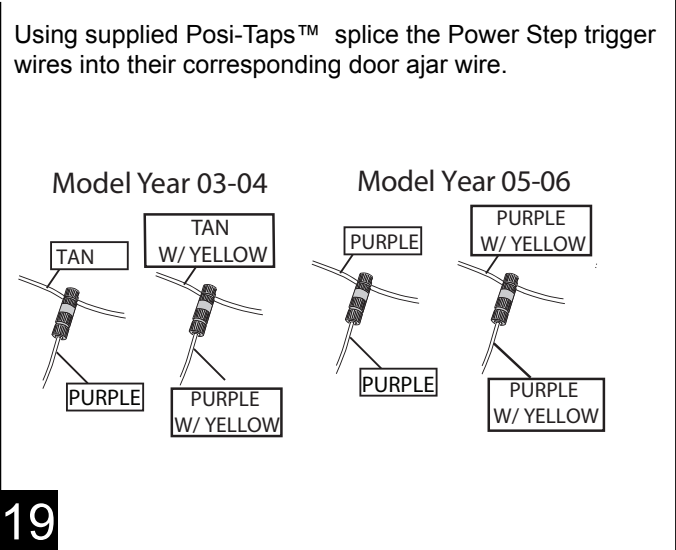
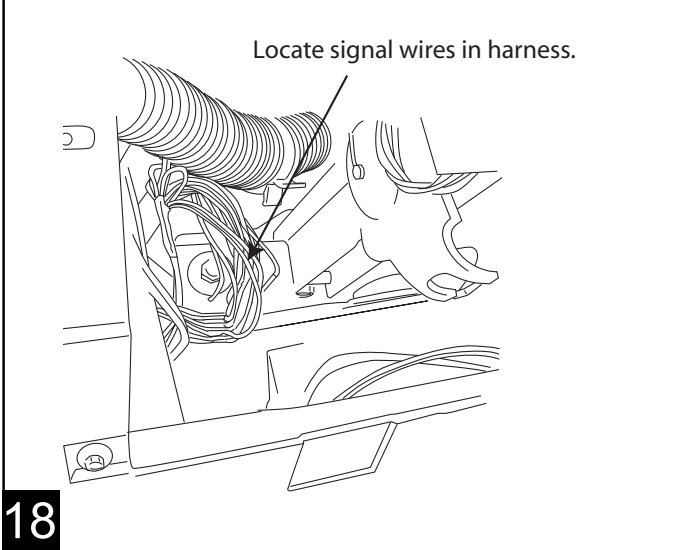



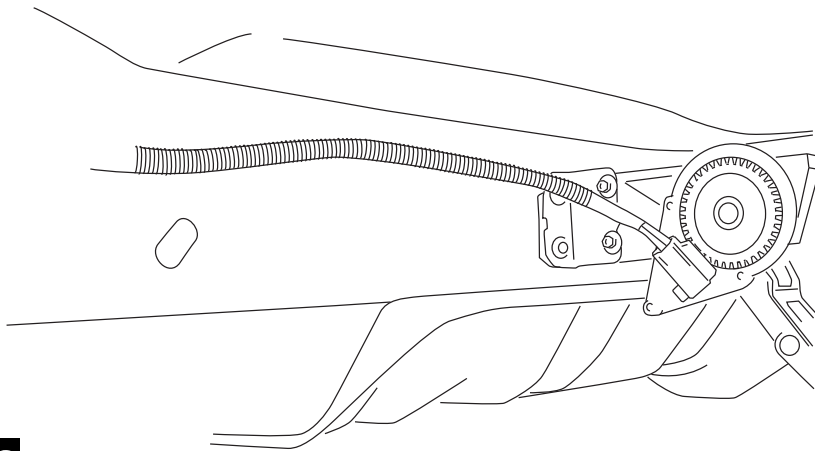

Route harness back to driving linkage assembly. Secure with cable ties.

22

Install motor. Board may have to be lifted up to have gears mesh correctly. Tighten bolts to 80 in-lbs (9 N-m).

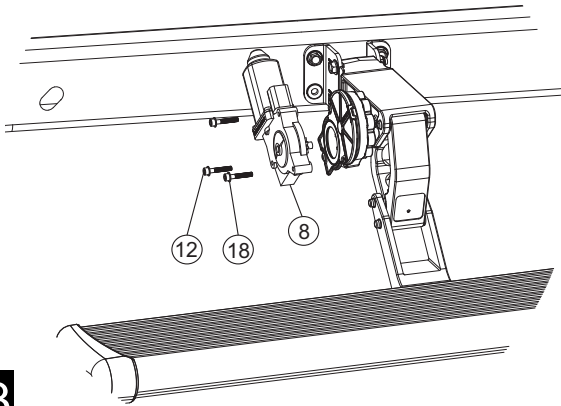

23

Connect harness to motors

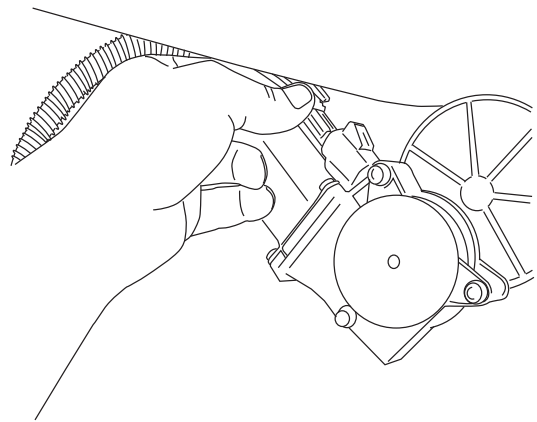

24

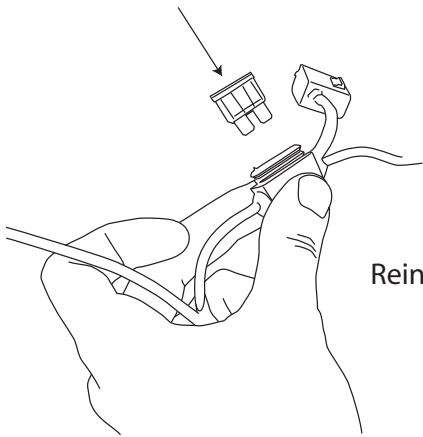

Reinstall fuse.

25

Open doors to test.

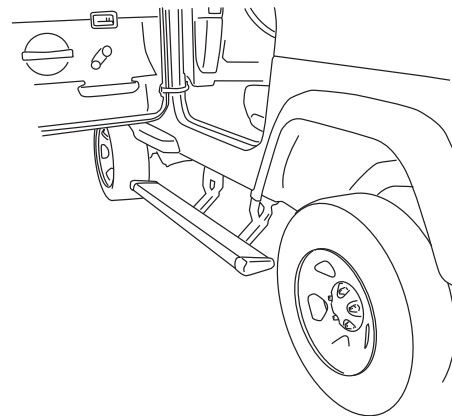

26

## LIMITED WARRANTY

AMP RESEARCH warrants product to be free from defects in material and workmanship, for terms specified below, provided there has been normal use and proper maintenance. This warranty applies to the original purchaser only. All remedies under this warranty are limited to the repair or replacement of any item found by the factory to be defective within the time period specified.

If you have a warranty claim, first you must call our factory at the number below for instructions. You must retain proof of purchase and submit a copy with any items returned for warranty work. Upon completion of warranty work, if any, we will return the repaired or replaced item or items to you freight prepaid. Damage to our products caused by accidents, fire, vandalism, negligence, misinstallation, misuse, Acts of God, or by defective parts not manufactured by us, is not covered under this warranty.

THE WARRANTY TIME PERIOD IS AS FOLLOWS: THREE YEARS FROM DATE OF PURCHASE.

ANY IMPLIED WARRANTIES OF MERCHANTABILITY AND/OR FITNESS FOR A PARTICULAR PURPOSE CREATED HEREBY ARE LIMITED IN DURATION TO THE SAME DURATION AND SCOPE AS THE EXPRESS WRITTEN WARRANTY. OUR COMPANY SHALL NOT BE LIABLE FOR ANY INCIDENTAL OR CONSEQUENTIAL DAMAGE.

Some states do not allow limitations on how long an implied warranty lasts, or the exclusion or limitation of incidental or consequential damages, so the above limitations or exclusions may not apply to you.

This warranty gives you specific legal rights, and you may also have other rights that vary from state to state.

For further information or request for warranty work, please call toll-free 1-888-983-2206 (press 5) for Customer Service.

## WARNING

The manufacturer strongly recommends that this product be professionally installed.

Failure to carefully follow the electrical installation steps could result in severe electrical shock that could harm the installer and/or damage the vehicle.

This product is designed to enhance the appearance of the vehicle. Do not rely in any way on the components of this product to contain occupants within the vehicle, or to protect against injury or death in the event of an accident. Never operate vehicle in excess of manufacturer's specifications.

**WEAR SEAT BELTS AT ALL TIMES**

Read and follow, precisely, all installation instructions provided when installing this product. Failure to do so could place occupants of the vehicle in a potentially dangerous situation. After installing or reinstalling, check to make sure it has been properly installed.